

This article was downloaded by: [209.222.7.236]

On: 10 September 2014, At: 14:02

Publisher: Routledge

Informa Ltd Registered in England and Wales Registered Number: 1072954 Registered office:
Mortimer House, 37-41 Mortimer Street, London W1T 3JH, UK



The Quarterly Journal of Experimental Psychology

Publication details, including instructions for authors and subscription information:

<http://www.tandfonline.com/loi/pqje20>

The effect of blocking inter-trial interval on sequential effects in absolute identification

Chris Donkin^a, Vivian Chan^a & Sophia Tran^a

^a School of Psychology, University of New South Wales, Sydney, Australia

Published online: 09 Sep 2014.

To cite this article: Chris Donkin, Vivian Chan & Sophia Tran (2014): The effect of blocking inter-trial interval on sequential effects in absolute identification, The Quarterly Journal of Experimental Psychology

To link to this article: <http://dx.doi.org/10.1080/17470218.2014.939665>

PLEASE SCROLL DOWN FOR ARTICLE

Taylor & Francis makes every effort to ensure the accuracy of all the information (the "Content") contained in the publications on our platform. However, Taylor & Francis, our agents, and our licensors make no representations or warranties whatsoever as to the accuracy, completeness, or suitability for any purpose of the Content. Any opinions and views expressed in this publication are the opinions and views of the authors, and are not the views of or endorsed by Taylor & Francis. The accuracy of the Content should not be relied upon and should be independently verified with primary sources of information. Taylor and Francis shall not be liable for any losses, actions, claims, proceedings, demands, costs, expenses, damages, and other liabilities whatsoever or howsoever caused arising directly or indirectly in connection with, in relation to or arising out of the use of the Content.

This article may be used for research, teaching, and private study purposes. Any substantial or systematic reproduction, redistribution, reselling, loan, sub-licensing, systematic supply, or distribution in any form to anyone is expressly forbidden. Terms & Conditions of access and use can be found at <http://www.tandfonline.com/page/terms-and-conditions>

The effect of blocking inter-trial interval on sequential effects in absolute identification

Chris Donkin, Vivian Chan, and Sophia Tran

School of Psychology, University of New South Wales, Sydney, Australia

Sequential effects are ubiquitous in decision-making, but no more than in the absolute identification task where participants must identify stimuli from a set of items that vary on a single dimension. A number of competing explanations for these sequential effects have been proposed, and recently Matthews and Stewart [(2009a). The effect of inter-stimulus interval on sequential effects in absolute identification. *The Quarterly Journal of Experimental Psychology*, 62, 2014–2029] showed that manipulations of the time between decisions is useful in discriminating between these accounts. We use a Bayesian hierarchical regression model to show that inter-trial interval has an influence on behaviour when it varies across different blocks of trials, but not when it varies from trial to trial. We discuss the implications of both our and Matthews and Stewart's results on the effect of inter-trial interval for theories of sequential effects.

Keywords: Absolute identification; Sequential effects; Bayesian inference; Inter-trial interval; Decision-making.

Absolute identification has seen fruitful study for more than half a century (Brown, Marley, Donkin, & Heathcote, 2008; Lacouture & Marley, 1995; Luce, 1986; Marley & Cook, 1984; Miller, 1956; Pollack, 1952; Stewart, Brown, & Chater, 2005; Triesman & Williams, 1984; and the extensive citations in these works). In a typical absolute identification task, participants must identify a single stimulus from a set of K items that vary across one dimension (e.g., brightness, intensity, length). For example, 10 tones differing only in their intensity would be assigned the labels #1 to #10, in order of their intensity. On any given trial, one tone is played, and the participant must respond with the corresponding label.

A hallmark of absolute identification is that the stimuli and responses from earlier trials influence

judgements on the current trial (Stewart et al., 2005). Assimilation is one such sequential effect, where responses made to the stimulus presented on the current trial tend to be biased towards the response made on the preceding trial. For example, participants are more likely to overestimate the current stimulus if its intensity is less than the stimulus presented on the previous trial. A second sequential effect, known as contrast, occurs when the current response is biased away from stimuli presented on earlier trials. Thus, errors tend to be overestimates if earlier stimuli are small, and underestimates if earlier trials are large. The dynamics of assimilation and contrast effects are such that there is strong, but short-lasting, assimilation to the response on the preceding trial, and weaker but long-lasting contrast to

Correspondence should be addressed to Chris Donkin, School of Psychology, University of New South Wales, Kensington NSW 2052, Australia. E-mail: christopher.donkin@gmail.com

Chris Donkin's contribution to this research was supported by his Australian Research Council Discovery Early Career Award (DE130100129) and Discovery Project (DP130100124). We also wish to thank Scott Brown for his helpful comments on an earlier version of this manuscript.

stimuli on previous trials. As such, we observe an assimilation effect for trial $n - 1$ and a contrast effect for earlier trials (Mori & Ward, 1995).

Sequential effects are such a robust phenomenon in absolute identification, differing only in magnitude as a function of task difficulty (Ward & Lockhead, 1971), that “a procedure cannot be made to avoid these effects” (Luce, 1986) and this appears to be true thus far as there is “no absolute identification experiment in which strong sequential effects ... were not found” (Stewart et al., 2005). Such sequential effects are also present throughout other paradigms in cognitive psychology, including categorization and exemplar production (Zotov, Jones, & Mewhort, 2011), judgements of price (Matthews & Stewart, 2009b), and recognition memory (Malmberg & Annis, 2012).

As such, there are many theories of assimilation and contrast. For example, Holland and Lockhead (1968) proposed that the memory for the current stimulus is contaminated by the memories of previously encountered stimuli. The recency of the stimulus determines the degree to which it contaminates identification, and assimilation is assumed to be the result of the most recent stimulus, while contrast occurs as a result of stimuli presented further back in the sequence of trials. For example, consider the case in which a small stimulus was presented on the previous trial. This means that, on average, the stimuli presented on earlier trials were larger stimuli. The memories for these larger earlier stimuli interfere with the judgement of the distance between the previous and current stimulus in a way that causes the distance to be underestimated. Hence, a response based on this distance will assimilate to the stimulus presented on the previous trial (and therefore away from the larger stimuli on earlier trials). Though the Holland and Lockhead account has been shown to be inadequate, Stewart et al. (2005) provided an up-to-date and more successful account of absolute identification in terms of relative judgement.

An alternative explanation for sequential effects is provided by the Selective Attention Mapping and Ballistic Accumulation (SAMBA; Brown

et al., 2008) model. SAMBA is made up of three stages. The first, a selective attention stage, establishes an upper and lower limit for the range spanned by the stimuli (e.g., a quietest and loudest tone). These limits act as anchors, and rehearsal activity is used to maintain an internal context between these anchors. When a stimulus is presented, it is projected onto this context, and the magnitude of the stimulus is estimated as the proportion of rehearsal activity between the stimulus and the lower anchor, relative to the total amount of rehearsal activity (i.e., an estimate of the relative position of the stimulus within the context of the experiment). The mapping stage of SAMBA then transforms the magnitude estimate into evidence strengths for each of the K possible response alternatives. In the final stage, these evidence strengths determine the rate at which evidence is collected in each of K ballistic accumulators. The response accumulators collect evidence for each possible response until one such accumulator reaches a threshold amount of evidence, and this determines the response and the time taken to make the decision.

The SAMBA model explains the sequential effects of assimilation and contrast in terms of two additional assumptions. Contrast effects are a result of the first, selective attention stage. The magnitude estimate for the stimulus on trial n is made by summing the rehearsal activity between the stimulus representation and the lower and upper anchors (Σ_L and Σ_U , respectively). However, instead of this rehearsal activity being distributed randomly across the experimental context, it is preferentially redirected to the stimulus presented on trial $n - 1$. This extra rehearsal increases the activity between stimulus n and one of the anchors, thus increasing either Σ_L or Σ_U . The increase in Σ either decreases or increases the magnitude estimate for stimulus n depending on whether stimulus n is smaller or larger than stimulus $n - 1$, respectively (i.e., it produces contrast).

For example, imagine trying to identify a #4 stimulus. If the previous stimulus was a #1, then there is additional rehearsal activity at that location. The extra activity at #1 will increase the amount of activity between the lower anchor and the current

stimulus, Σ_L . Since the magnitude estimate is $\frac{\Sigma_n}{\Sigma_L + \Sigma_U}$, the current stimulus will appear larger, and so the current response will be biased away from the previous stimulus.

Assimilation in SAMBA is assumed to result via the following process. Activation in the evidence accumulators used to make decisions is assumed to decay during the time between decisions (inter-trial interval; ITI), so as to return evidence back to resting levels. The level of residual activity in each of the accumulators determines the starting position of evidence accumulation on the next trial. The accumulators closer to threshold on trial $n - 1$ decay from higher activation, and so begin the decision process with more evidence on trial n . This extra activation increases the probability that the same (or a similar) response will be repeated.

The assimilation to previous responses and contrast to previous stimuli in SAMBA combine to produce assimilation to the response from trial $n - 1$, where the passive decay assimilation mechanism dominates performance, and contrast for stimuli on trials $n - 2$ and further back.

Matthews and Stewart (2009a) sought to discriminate between the alternative accounts for assimilation and contrast by manipulating the time between decisions. They explained that different models of sequential effects make different predictions about the influence of manipulating ITI. For example, a model that assumes interference from memories of previous representations, such as the Relative Judgement Model of Stewart et al. (2005), predicts a reduction in sequential effects with increased ITI. That is, assuming that the strength of memory for previous items decays with time, then with more time between trials memory will weaken further, and thus interfere less with the current decision.

Like other models, the SAMBA model also predicts that assimilation to previous responses should decrease with increased ITI. However, unlike other models, SAMBA predicts that contrast will increase with ITI. The reduction in assimilation comes about because of the passive decay of activity in response accumulators. Longer ITI allows the starting activity in all accumulators to return to baseline levels, thus reducing assimilation to the

previous response. The increase in contrast is a by-product of the reallocation of attention to the representation of the previous stimulus. If this selective attention is allowed to continue for a longer time, due to an increased ITI, the contrast effect will increase in magnitude.

Matthews and Stewart (2009a) manipulated the time between trials to be either 500 ms or 5500 ms, both between and within blocks of trials in two otherwise standard absolute identification experiments. They used a regression analysis to investigate the influence of previous stimuli and previous responses. Responses from participants were fit with an equation in which both stimuli and responses were included as predictors:

$$R_n = \lambda + \alpha_0 S_n + \alpha_1 S_{n-1} + \beta_1 R_{n-1} + \alpha_2 S_{n-2} + \beta_2 R_{n-2} + \epsilon,$$

where R_i is the response made on the i th trial, S_i is the stimulus presented on the i th trial, λ is an intercept term, and ϵ is a normally distributed error term.

Using this regression equation, Matthews and Stewart (2009a) showed that longer ITI increased contrast to stimuli presented on trial $n - 1$ and trial $n - 2$ (i.e., α_1 and α_2 both became more negative when ITI increased). On the other hand, assimilation to the response from trial $n - 1$ was unaffected by ITI (i.e., β_1 was the same in both ITI conditions). This pattern of results was consistent with the predictions of the selective-attention mechanism of SAMBA, as it predicts larger contrast to previous stimuli with increased ITI. However, the lack of an effect of ITI on the size of the assimilation to the previous response calls into question the account of sequential effects given by the passive decay process for assimilation in SAMBA, as well as all other models of sequential effects, including the memory-based explanations discussed earlier (e.g., Stewart et al., 2005).

Matthews and Stewart's (2009a) investigation into ITI helped us to better understand sequential effects. Our aim here is to follow up on their work and provide additional understanding of the influence of the time between decisions on absolute

identification performance. So as to better understand the time course of sequential effects, we use ITI conditions that fall between the two extreme values used in Matthews and Stewart (500 ms and 5500 ms).

Under the heading of Experiment 1, we report the results of two experiments that formed part of a series of three experiments. We omit the details of the first experiment, as it was a successful replication of Matthews and Stewart's (2009a) Experiment 1, where all aspects of the design were identical, except that we used different stimuli. In the second experiment, we manipulated ITI from trial to trial, but no longer observed an effect of ITI on sequential effects. In a third experiment, we did observe an effect of ITI on sequential effects when ITI was consistent within a block of trials, but varied between blocks. We now report the results of our second and third experiments, but present them together to facilitate comparison.

EXPERIMENT 1

Method

Participants

A total of 73 first-year psychology students from the University of New South Wales took part in the experiment in exchange for course credit. 42 participants completed the task in the within-block ITI manipulation condition, and 31 participants took part in the between-blocks ITI manipulation condition.

Stimuli

Each stimulus consisted of an array of black dots (4 mm in size), presented on a white background. The number of dots varied between 11 to 90 dots (inclusive) and were presented in randomly chosen locations in a 9×10 grid in the centre of a 24" LCD monitor (resolution 1920×1080). To avoid the dots falling in a uniform grid, a jitter of at least ± 0.56 mm was added to the position of each dot both horizontally and vertically. Such jitter makes it harder for participants to explicitly count the dots. Also, to avoid the possibility

that participants recalled a specific array of dots, a new set of stimuli was generated for each block of trials, ensuring that no participant saw the same array of dots more than once.

Design and procedure

The ITI was either 500 ms, 1000 ms or 2200 ms. ITI varied either between blocks of trials or within a block of trials. In the within-block ITI condition, participants completed 5 blocks of 80 trials. The order of ITI conditions was random, but within a block, each stimulus was preceded by each ITI three times (since each stimulus was presented ten times, the remaining trial for each stimulus was preceded by a randomly chosen ITI). In the between-blocks ITI condition, participants completed 6 blocks of 72 trials and the order of ITI conditions was randomized, with the exception that the two blocks of each ITI condition were presented consecutively. Participants were told at the start of the experiment that the time between trials would vary during the task. Participants in the within-block condition were told that ITI would change from trial to trial, and participants in the between-blocks condition were told at the beginning of each block whether the time between trials would be relatively short, moderate or long. The time between blocks was self-paced, though participants were encouraged to take a break lasting for about one minute.

At the beginning of each trial, a fixation cross appeared in the middle of the screen for 300 ms before one of the possible arrays of between 11 to 90 dots was shown. The stimuli remained on-screen until a response was made. Participants had to categorize the number of dots into one of 8 categories. Participants needed to press "S" if they thought there were 11–20 dots in the array, "D" for 21–30 dots, "F" for 31–40 dots, "G" for 41–50 dots, "H" for 51–60 dots, "J" for 61–70 dots, "K" for 71–80 dots and "L" for 81–90 dots. Participants were asked to place their left index finger on "G" and right index finger on "H" and let every other finger fall on the keys that follow on either side. Eight rectangles corresponding to the response categories, "11–20", "21–30", etc. acted as response cues and were shown below the

stimulus on each trial. When a response was selected, the corresponding response cue was highlighted by making bold the outline of the rectangle, while the unselected response cues disappeared. The stimulus was replaced by the correct response in green font to indicate an accurate judgement, or in red font if participants produced an incorrect response. This feedback remained on-screen for 500 ms before a blank screen was shown for a duration corresponding to the chosen ITI for that trial, or block of trials, depending on the ITI manipulation condition. The fixation cross appeared again to signal the next trial.

Participants first completed a self-paced practice block of 40 trials (with an ITI of 0 ms). Practice trials were identical to the experimental trials, except that in the experimental trials participants were required to respond within 1700 ms, or they would receive “TOO SLOW” instead of the usual feedback. The emphasis on fast responding was used to encourage participants to make estimates as quickly as possible and not utilize higher-level strategic counting. Participants were also informed that stimuli from all categories would be presented an equal number of times to minimize any bias to overuse or underuse certain response categories.

Results

In order to remove responses that may have been contaminated by other processes such as strategic counting methods or pre-emptive button presses, trials were removed from the data if the corresponding response time was slower than 1700 ms or faster than 200 ms. This led to 1% of trials being eliminated. The first 3 trials of each block were removed so that only responses preceded by enough trials to be influenced by sequential effects were analysed. Finally, the three trials that followed a “too slow” message were also removed, since we provided no feedback on accuracy on such trials, and therefore may have disrupted sequential effects. Less than 2% of the data were removed due to slow responses.

Sequential effects in absolute identification are usually investigated using impulse plots. Figure 1 shows the average error on trial n on the y-axis, as

a function of the number of trials, x , before n on the x-axis. The separate lines in each plot represent the size of the stimuli presented on trial $n - x$. Note that there are 4 lines instead of 8, because we averaged together adjacent responses, i.e., categories 11–20 and 21–30 were averaged together, 31–40 and 41–50 were averaged together, etc. Such averaging reduces the noise in the impulse plots (Matthews & Stewart, 2009a; Ward & Lockhead, 1970).

The leftmost set of points in each plot in Figure 1 reveals the size of the assimilation effect. Larger separation between these points is indicative of greater assimilation of responses to the stimulus from the previous trial. The centre and rightmost points in each plot show contrast to the stimuli presented on trials $n - 2$ and $n - 3$. The switch from assimilation to contrast is clear from the figure. For example, negative errors when the stimulus on trial $n - 1$ is small become positive errors on trial $n - 2$.

The top row of impulse plots are very similar, suggesting that there is relatively little influence of ITI on sequential effects when ITI was manipulated within blocks of trials. On the other hand, the plots in the bottom row suggest that there may be a reduction in the assimilation effect for stimuli on trial $n - 1$ when ITI was manipulated between blocks of trials. We now apply a Hierarchical Bayesian implementation of the regression analysis used in Matthews and Stewart (2009a) to determine whether the reduction is due to a decrease in the assimilation to the previous response, or an increase in contrast to the previous stimulus.

Regression analysis

Figure 2 contains a graphical model depiction of the regression model that was fit to the data from the within-block and between-block conditions (for more details on Bayesian statistics and graphical models for cognitive psychology, see Griffiths, Kemp, & Tenenbaum, 2008; Jordan, 2004; Lee, 2008; Lee & Wagenmakers, 2014; Shiffrin, Lee, Kim, & Wagenmakers, 2008). The model is identical to the linear regression model used by Matthews and Stewart (2009a) described earlier. However, the model also assumes that each

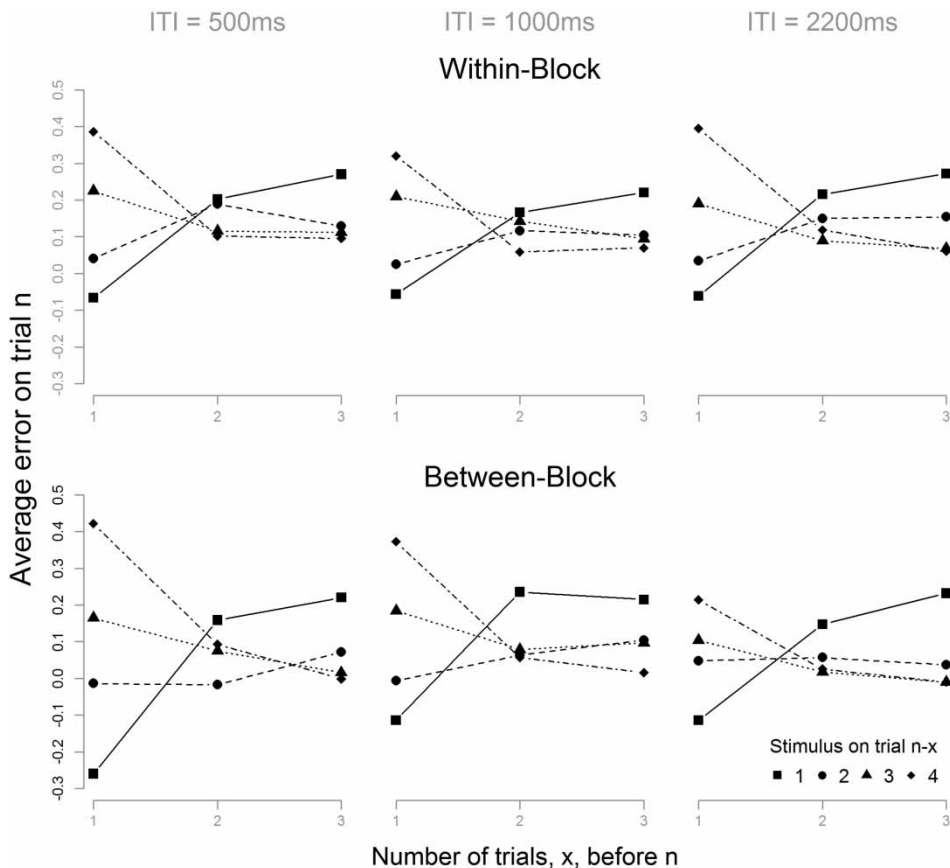

Figure 1. The assimilation and contrast effects in the within-block and between-blocks ITI manipulation conditions in Experiment 1. Average error on trial n is plotted as a function of the number of trials, x , before n on the abscissa. The different lines represent the size of the stimulus presented on trial $n - x$.

individual participant's regression parameters come from a population of regression parameters that is normally distributed. We will focus our analysis on the mean of these hierarchical distributions (i.e., α s and β s). Our inference will be on the parameters defining the difference between regression parameters across ITI conditions (i.e., $\Delta\alpha$ s and $\Delta\beta$ s).

Posterior distributions for all parameters were sampled using 6 Markov-chain Monte Carlo chains of 100,000 iterations, with a burn-in of 2000. We retained 1 in 50 iterations to remove the influence of autocorrelation within chains. This resulted in posterior distributions for each

parameter based on 11,760 samples. Table 1 reports the median of the posterior distribution for the α and β parameters.

Table 1 also contains the results of Savage-Dickey tests on the posteriors for the $\Delta\alpha$ and $\Delta\beta$ parameters (i.e., the difference between the 500 ms and 1000 ms, and 500 ms and 2200 ms ITI conditions; Wagenmakers, Lodewyckx, Kuriyal, & Grasman, 2010). This procedure compares the height of the posterior distribution at zero to the height of the prior distribution at zero. This ratio gives a measure of the likelihood of the data under the hypothesis that the parameter is not zero, relative to the likelihood that the parameter

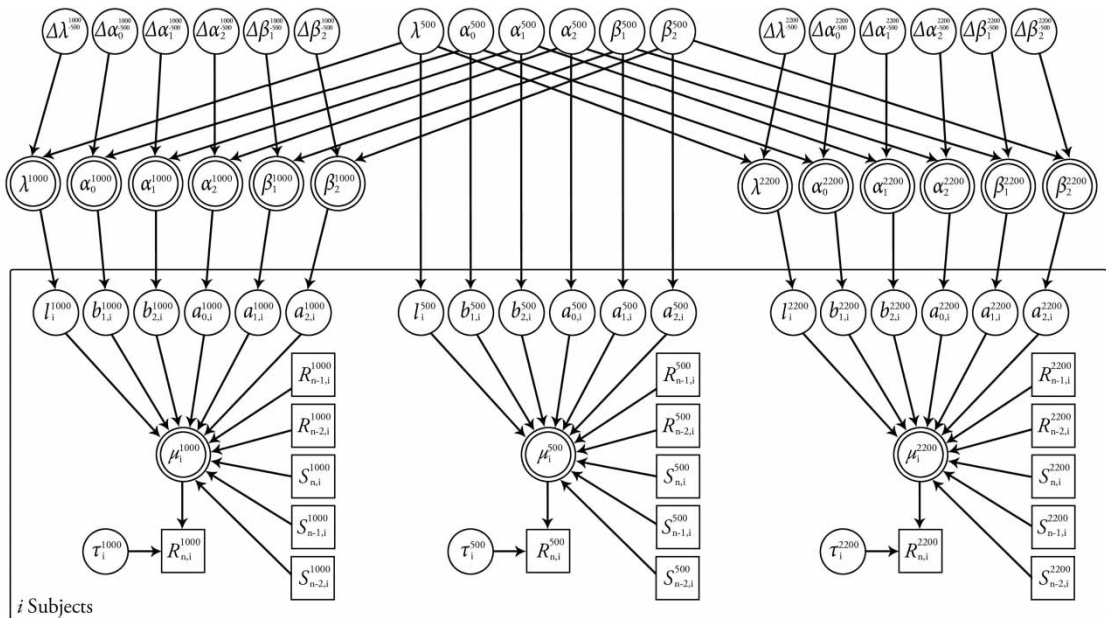

Figure 2. Graphical model of the hierarchical Bayesian regression fit to the data from the within-block and between-blocks conditions in Experiment 1. Note that $\mu = l + a_0 S_n + a_1 S_{n-1} + a_2 S_{n-2} + b_1 R_{n-1} + b_2 R_{n-2}$, where S_i is the stimulus on trial i , and R_i is the response on trial i . The responses on trial n , R_n , are normally distributed with mean μ and standard deviation τ . Individual participant regression coefficients l , a , and b , are drawn from normal distributions with means λ , α , and β , and standard deviation σ (note that σ is not shown in the figure, but is the same for all hierarchical distributions). The differences in the means of the hierarchical distributions between the 500 ms ITI conditions and 1000 ms and 2200 ms ITI conditions are represented by $\Delta\lambda$, $\Delta\alpha$, and $\Delta\beta$. The prior distribution on λ^{500} , α^{500} and β^{500} parameters was a Normal with mean of 0 and variance of 1000. The prior on Δ parameters was Uniform distribution between -0.3 and 0.3 . The prior on σ was a gamma distribution with both parameters set at 0.001. The prior on τ was a uniform distribution with range 0.01 to 10.

is zero (i.e., the null hypothesis). Values greater than one suggest that the data are more likely under the alternative hypothesis than under the null hypothesis, while values less than one suggest that the null hypothesis is more likely. Since our Bayes factors are on the $\Delta\alpha$ and $\Delta\beta$ parameters, the null hypothesis is that there is no difference between the two ITI conditions, and the alternative hypothesis is that there is a difference between the two ITI conditions.

According to these analyses, the stimulus on trial $n - 1$ produced more contrast when ITI was longer, but only in the between-blocks condition, and only when the difference between ITI was largest. Figure 3 plots the posterior distributions for the $\Delta\alpha_1$ parameters (i.e., the difference between α_1 in the 500 ms ITI condition and the 1000 ms and 2200 ms ITI conditions) for the

within-block and between-blocks conditions. With the exception of the difference between 500 ms and 2200 ms ITI in the between-blocks condition, all posterior distributions have substantial mass at zero, reflecting a general lack of influence of ITI on contrast to the previous stimulus. The Bayes factors in Table 1 confirm this interpretation; the data from the within-block condition are 11 times (i.e., $1/0.09$) more likely under the null hypothesis, suggesting that there is no difference between α_1 at ITIs of 500 ms and 2200 ms. Similarly, the difference between 500 ms and 1000 ms ITI conditions are 5 and 4 times more likely under the null hypothesis for the within-block and between-blocks conditions, respectively. It is only the difference between 500 ms and 2200 ms ITI conditions in the between-blocks condition that the data are more likely under the

Table 1. Median posterior samples for regression coefficients estimating the effect of stimuli on trials n , $n - 1$, and $n - 2$ and responses on trial $n - 1$ and $n - 2$ on the response made on trial n in Experiment 1

ITI	Predictor	Median			BF	
		ITI			Difference	
		500 ms	1000 ms	2200 ms	1000 ms – 500 ms	2200 ms – 500 ms
Within-Block						
	S_n	.887	.884	.871	0.05	0.14
	S_{n-1}	.016	-.01	.014	0.20	0.09
	S_{n-2}	-.048	-.062	-.045	0.11	0.08
	R_{n-1}	.063	.077	.057	0.11	0.09
	R_{n-2}	.029	.045	.022	0.11	0.09
Between-Blocks						
	S_n	.862	.877	.887	0.11	0.38
	S_{n-1}	.027	.003	-.036	0.24	2.73
	S_{n-2}	-.016	-.064	-.077	0.74	2.05
	R_{n-1}	.088	.076	.088	0.12	0.11
	R_{n-2}	-.001	.033	.050	0.29	0.93

Note: Savage–Dickey Bayes factors (BF) are given for the difference between the 500 ms and 1000 ms ITI conditions, and the 500 and 2200 ms ITI conditions. BF's greater than 1 reflect evidence for the hypothesis that there is a difference between the two ITI conditions. BF's less than 1 reflect evidence in favour of the null hypothesis that there is no difference between the two ITI conditions.

alternative hypothesis than the null hypothesis (Bayes factor is 2.73).

The stimulus presented on trial $n - 2$ also produced larger contrast when ITI was 2200 ms compared to when ITI was 500 ms, but again this was only for the between-blocks condition. Bayes factors suggested that the data in the within-block are between 11 and 13 times more likely under the null hypothesis of no difference between ITI conditions. The difference between 500 ms and 1000 ms ITI conditions in the between-blocks condition was 1.4 times more likely under the null hypothesis. It was only the difference between α_2 for 500 ms and 2200 ms ITI conditions in the between-blocks that provided evidence more likely under the alternative hypothesis (approximately twice as likely as the null).

The difference between assimilation to prior responses for different ITI conditions was never more likely under the alternative hypothesis, and most often provided considerable evidence for the null hypothesis. For example, assimilation to the response on trial $n - 1$ was never influenced by ITI (the data were at least 8 times as likely under the null hypothesis in all comparisons).

Discussion

When ITI was manipulated between blocks, our pattern of sequential effects was in line with those from Matthews and Stewart (2009a). We found that assimilation was unaffected by ITI, while contrast to stimuli from trials $n - 1$ and $n - 2$ increased when ITI increased from 500 ms to 2200 ms. However, when ITI varied from trial to trial it had no effect on sequential effects. Unlike Matthews and Stewart, we failed to see an increase in contrast to previous stimuli when ITI was longer.

The lack of an impact of ITI in our within-block condition is at odds with Matthews and Stewart's (2009a) Experiment 2, where contrast to prior stimuli increased with ITI, even when it changed from trial to trial. One possible reason for this discrepancy may lie in the ITI values used. Matthews & Stewart (2009a) used a short ITI of 500 ms, and a long ITI of 5 seconds. This long ITI is considerably longer than our largest ITI, 2200 ms. It seems possible that an ITI of 5 seconds is functionally equivalent to blocking ITIs. That is, with ITI being either 500 ms or 5500 ms, participants are

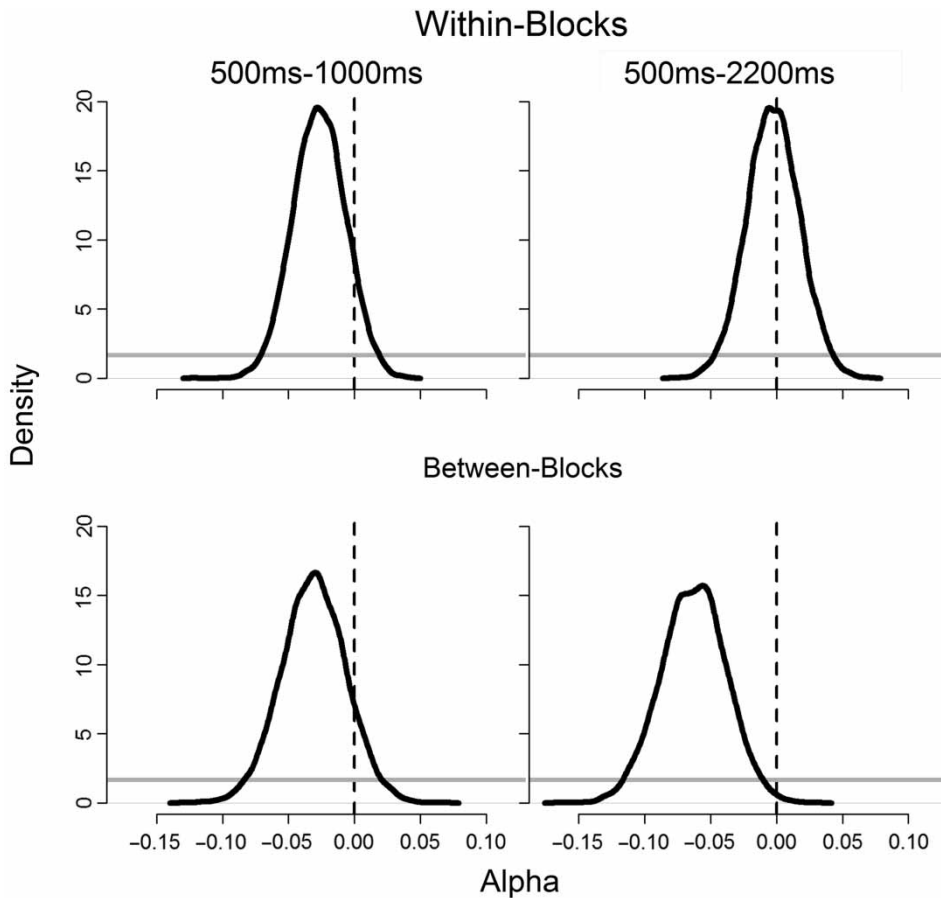

Figure 3. Posterior distributions for the difference in α_1 between 500 ms and 1000 ms ITI conditions (left column) and between 500 ms and 2200 ms conditions (right column) for the within-block (top row) and between-blocks (bottom row) conditions in Experiment 1. The grey horizontal line represents the height of the prior distribution for the difference in α_1 . The relative heights of the posterior and prior distributions at the vertical dotted line (at zero) reflect the Bayes factors given in Table 1.

quickly able to determine whether they are going to have a short or a long break between trials, and make any strategic adjustments to their behaviour that they so desire. This seems more difficult when ITI only varies from 500 ms to 2200 ms, since by the time one can realize there is a longer break between trials, the next trial is about to start.¹

Since the results of our within-block condition were not consistent with those in Matthews and

Stewart (2009a), it is prudent to see if our result can be replicated. Further, the Bayes factors we observed provided only weak evidence of any difference between contrast effects across the ITI conditions (a Bayes factor of 2.7 would be barely worth a mention according to Jeffreys 1961). As such, we carried out an experiment designed to replicate the results from Experiment 1 in a purely within-subjects design. In particular, we aimed to replicate the null effect of ITI when

¹It is also possible that the stimuli, which were different in our experiments, are the cause of the difference between the two results. Our initial replication of the two experiments was so similar that we doubt this possibility, but future empirical work is needed.

manipulated within blocks of trials, and show that contrast to previous stimuli increases with ITI when manipulated between blocks of trials.

EXPERIMENT 2

Method

A total of 40 first-year psychology students at the University of New South Wales participated in exchange for course credit. The procedure for individual trials and the stimuli were identical to that in Experiment 1. However, the design was different in a number of ways. First, ITI was either 0 ms or 2000 ms. Second, participants completed a total of 4 blocks of 80 trials. In 2 blocks ITI varied randomly from trial to trial (with the restriction that there were 40 trials of each ITI per block), while in the other 2 blocks ITI remained constant at either 0 ms or 2000 ms for the entire block. The order of the blocks were counterbalanced, such that half of the participants first completed the two blocks of within-block manipulation of ITI, and the other half first completed the two blocks of the between-blocks ITI condition. Of those participants, when doing the between-blocks condition, half completed the 2000 ms ITI block first and the other half completed the 0 ms ITI block first.

Results

Data censoring was done as per Experiment 1 (5% of the data were removed in total). Figure 4 contains impulse plots for each of the ITI conditions for the within-block and between-blocks conditions. The empirical data appear to replicate the results of Experiment 1. The data look very similar to that of Figure 1, showing the characteristic assimilation to stimuli on trial $n - 1$ and contrast to stimuli on earlier trials. Also, we see that the size of the assimilation effect does not appear to

decrease from the 0 ms to 2000 ms ITI condition when ITI was manipulated within blocks. On the other hand, the assimilation effect does decrease with ITI in the between-blocks condition. We now confirm the reliability of this replication using the same regression analysis as in Experiment 1.

Regression Analysis

The regression model fit to the data from Experiment 2 was identical to that in Experiment 1, except that there were only two ITI conditions. Posterior distributions were sampled in the same way as for Experiment 1. Table 2 contains the median posterior samples for each of the α and β parameters of the regression. The table also contains Bayes factors calculated using the Savage-Dickey procedure, again testing whether regression parameters differed between the two ITI conditions.

Figure 5 shows the posterior distribution of $\Delta\alpha_1$ (the difference between α_1 at 0 ms and 2000 ms conditions) for the within-block condition (top panel) and the between-blocks condition (bottom panel). The posteriors here are similar to those in Figure 3, where the within-block condition shows relatively little evidence for a difference between ITI conditions, while the between-blocks condition shows more reliable evidence for a difference. The Savage-Dickey test reveals that the data in the within-block condition are 7.7 times more likely under the null hypothesis of no effect of ITI on α_1 , while the data in the between-blocks condition are 6.98 times more likely under the hypothesis that there is a difference between α_1 for 0 ms and 2000 ms ITI conditions.² However, inconsistent with Experiment 1, the difference between α_2 in the 0 ms and 2000 ms ITI conditions was deemed about 4 times more likely under the null hypothesis in both the between-blocks and within-block conditions.

²A standard 2 (between-blocks vs. within-block) \times 2 (0 ms vs. 2000 ms ITI) ANOVA analysis on the α_1 regression coefficients also indicates a significant interaction, $F(1,38) = 4.38$, $p = .043$. However, whether or not $p < .05$ is conditional on the removal of an outlying participant. We prefer the Hierarchical Bayesian approach, as the hierarchical structure provides a more elegant means of dealing with this atypical participant. The one-step nature of the Bayesian regression also takes into account uncertainty in our estimates of α_1 parameters, unlike the two-step regression and then ANOVA analysis.

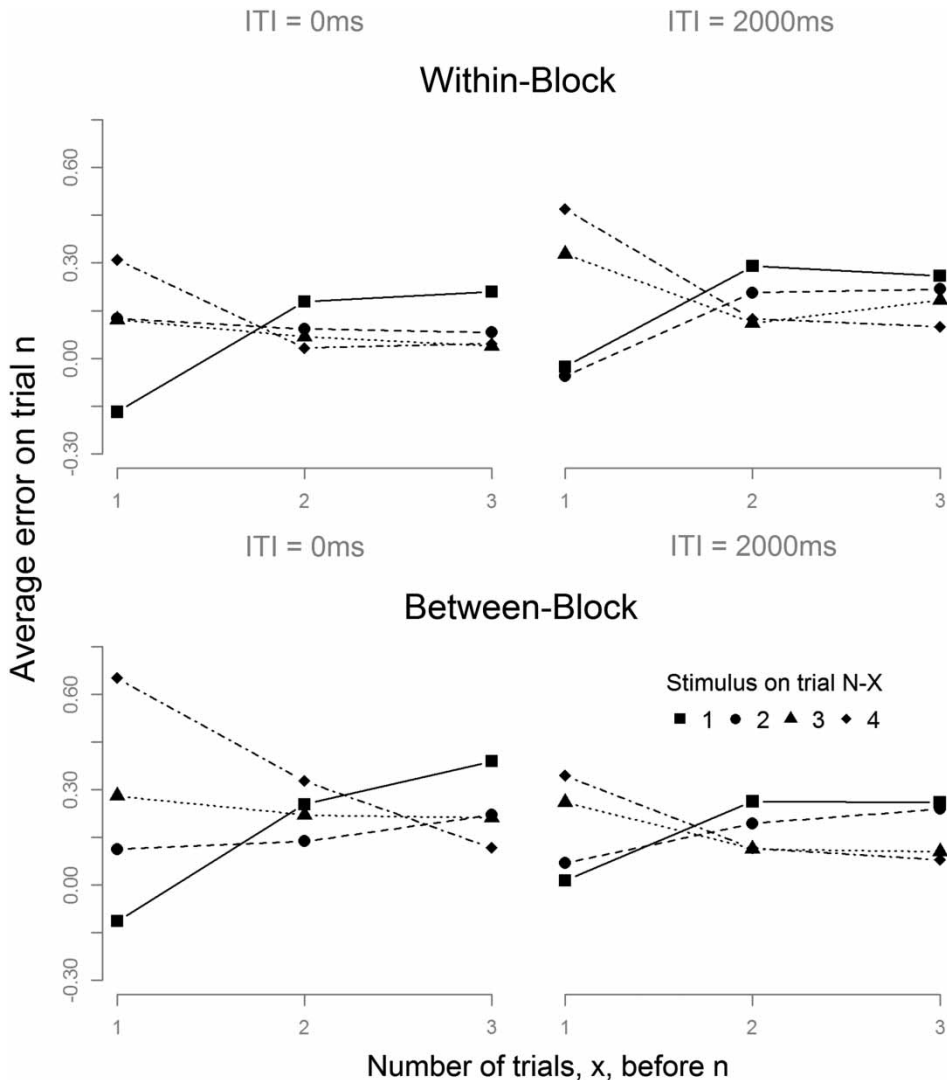

Figure 4. The assimilation and contrast effects in the within-block and between-blocks ITI manipulation conditions in Experiment 2. The format of the figure is identical to that of Figure 1.

Discussion

Experiment 2 successfully replicated two of the three major results in Experiment 1. First, we continued to observe evidence for no influence of ITI on sequential effects when it was manipulated within blocks of trials. Second, we observed an increase in the contrast to stimuli presented on trial $n - 1$ when ITI was longer and manipulated

between blocks. However, we failed to replicate the increase in contrast to stimuli presented on trial $n - 2$ when ITI was manipulated between blocks.

Since Bayes factors are dependent on prior distributions, one may wonder whether the lack of replication of the effect of ITI on contrast to the stimulus presented on trial $n - 2$ may be because of the particular prior we chose to use. First, we

Table 2. Median posterior samples for regression coefficients estimating the effect of stimuli on trials n , $n - 1$, and $n - 2$ and responses on trial $n - 1$ and $n - 2$ on the response made on trial n in Experiment 2

ITI	Predictor	Median		BF
		ITI		
		0 ms	2000 ms	Difference 2000 ms - 0 ms
Within-Block				
	S_n	.864	.898	0.72
	S_{n-1}	-.012	-.026	0.13
	S_{n-2}	-.049	-.055	0.11
	R_{n-1}	.083	.133	0.60
	R_{n-2}	.019	.019	0.11
Between-Blocks				
	S_n	.883	.910	0.81
	S_{n-1}	.033	-.043	6.98
	S_{n-2}	-.004	-.037	0.27
	R_{n-1}	.099	.108	0.12
	R_{n-2}	-.009	.001	0.12

Note: Savage-Dickey Bayes factors (BF) are given for the difference between the 0 ms and 2000 ms ITI conditions.

used the same priors for Experiment 2 as for Experiment 1, as we did not want any reported replication to be more likely simply because of our choice of prior. Second, in order for the data in Experiment 2 to provide evidence against the null hypothesis, we would have had to assume a prior distribution that was as narrow as the posterior distribution itself. In other words, our data provided little evidence of an effect of ITI on the contrast produced by the stimulus presented on trial $n - 2$.

On the more general issue of the choice of prior, we first note that we used a prior distribution on the effect of ITI on regression coefficients that was relatively uninformative. In particular, across the five experiments reported in Matthews and Stewart (2009a) and here, the change in coefficients across ITI conditions was essentially uniformly distributed from -0.05 to 0.11 . The prior distribution we used was a uniform distribution from -0.3 to 0.3 . As such, we granted our alternative hypothesis more flexibility than it required to account for the data, and as such, we only provide support for the

alternative hypothesis when the effect of ITI is relatively large. If we instead use a more informative prior such as a uniform distribution from -0.1 to 0.1 , then Bayes factors shift towards support for the alternative hypothesis, ranging from 0.33 to 21 (where the Bayes Factors in the original analysis vary from 0.11 to 6.98).

GENERAL DISCUSSION

The effect of ITI on sequential effects has proved useful for discriminating between models of absolute identification. Matthews and Stewart (2009a) found that contrast to prior stimuli was larger when ITI was longer. Our follow-up studies showed that this effect only occurs when ITI was consistent for a block of trials. As Matthews and Stewart (2009a) explained, the selective attention mechanism in SAMBA provides a natural account of the increase in contrast with ITI. More time between trials permits more rehearsal activity to be redirected to the location of the stimulus on trial $n - 1$, and so increases the bias away from the previous stimulus. Our results suggest that this redirection of rehearsal activity does not occur when ITI varies from trial to trial. One consequence of having ITI vary from trial to trial is that participants must remain vigilant in anticipation of the next stimulus. Perhaps this constant monitoring prevents the use of additional time between trials to redirect rehearsal activity to the previous stimulus. As such, participants can only use the extra time in longer ITI conditions to redirect activity to the $n - 1$ stimulus when ITI is predictable.

If ITI needs to be predictable to have an effect, then this may imply that the redirection of rehearsal activity requires attentional resources, or places demand on a central attentional bottleneck. Future experiments might test this hypothesis by having the ITI be predictable between trials, but filled with a distractor task designed to use attentional resources and thus interrupt the redirection of rehearsal activity. Without the opportunity for rehearsal, SAMBA would predict that we would see no increase in contrast with ITI.

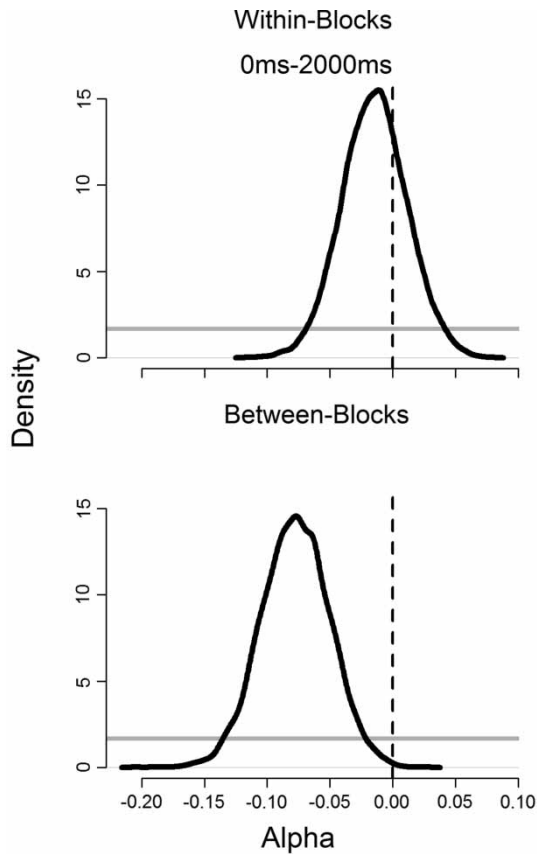

Figure 5. Posterior distributions for the difference in α_1 between 0 ms and 2000 ms ITI conditions for the within-block (top row) and between-blocks (bottom row) conditions in Experiment 2. The grey horizontal line represents the height of the prior distribution for the difference in α_1 . The relative heights of the posterior and prior distributions at the vertical dotted line (at zero) reflect the Bayes factors given in Table 2.

The most reliable result across both our and Matthews and Stewart's (2009a) study is that the assimilation to the response made on the previous trial, α_1 , is not influenced by ITI. This result is surprising, as it runs counter to most existing models of the assimilation effect. For example, the passive decay process in SAMBA predicts that assimilation to the previous response should decrease with increased ITI. One possible explanation for a lack of effect of ITI on assimilation is that activity in response accumulators does not decay with time. However, if activity does not decrease with time,

then accumulators would begin each trial with the same activity as they had at the end of the previous trial. As such, the accumulator that reached threshold on the previous trial would begin the current trial "at threshold", and thus the same response would be made on all subsequent trials. Instead, our results suggest the need for an alternative explanation of assimilation.

One way that assimilation could be produced is to assume that participants adjust the amount of evidence required to make a response on trial n based on the response made on trial $n - 1$. That is, participants might use adjustments to response thresholds to bias their responses to be like those made on the previous trial. It is important to assume that the degree to which thresholds are adjusted is proportional to the distance from the previous response, as simply reducing the threshold for only the previous response does not produce the gradual assimilation effect observed in data (see Stewart et al., 2005 for a discussion of the problem with this type of explanation of assimilation). Further, we must assume that any adjustments to thresholds made by a participant do not change with time, so as to prevent this alternative explanation from predicting an effect of ITI on assimilation.

One attractive benefit of assuming that assimilation is a result of threshold adjustments is that, in terms of implementation, it is very similar to the existing passive decay mechanism in the SAMBA model. The passive decay process produced assimilation because response accumulators with a lot of activity at the end of trial $n - 1$ had more starting activity at the beginning of trial n . A larger starting activity means that those accumulators require less evidence in order to reach threshold. In the threshold-based process we propose, it is assumed that starting activity is equal for all responses, but that participants adjust the amount of evidence required on the current trial. These two assumptions are functionally equivalent, which means that it is not necessary to refit SAMBA to existing data using the new assimilation mechanism. That is, this new assumption must work, in principle, because passive decay worked (except, of course, when it came to the effect of ITI).

This is not the first time that adjustment of response thresholds have been proposed to change. Thresholds have been assumed to change to produce systematic response bias (Van Ravenzwaaij, Mulder, Tuerlinckx, & Wagenmakers, 2012; White, Mumford, & Poldrack, 2012), or even throughout the course of a trial to ensure response termination (Luce, 1986; Viviani, 1979). An explanation of assimilation through threshold adjustment must assume that participants are able to quickly adjust their thresholds in response to their response on trial $n - 1$. In our experiment, the smallest amount of time between the response on trial $n - 1$ and the stimulus presentation on trial n was 1 second (500 ms of feedback + 0 ms ITI + 500 ms of fixation). Such rapid adjustments to response thresholds are atypical in standard decision-making models (e.g., Brown & Heathcote, 2008; Donkin, Brown, & Heathcote, 2011; Ratcliff & Rouder, 1998), because it is typically assumed that participants are unable to adjust response thresholds in response to some aspect of the current stimulus (but see King, Donkin, Korb, & Egner, 2012 for an exception). Such on-the-fly adjustment of thresholds may be more difficult because the decision-making process has already begun. Here, we propose that participants adjust their thresholds based on their own response (and so need no external cue to do so), and make these adjustments while the decision-making process is no longer underway.

One implication of this alternative theory for assimilation is that we should continue to observe an assimilation to previous responses even in the absence of feedback. Existing empirical data suggests that the influence of the previous response increases when participants are not given feedback (e.g., Mori & Ward, 1995). As such, we may have to further assume that the adjustments made after each trial are larger when participants are not told what the correct response was for that given trial. Interestingly, Mori and Ward (1995) also observed a large increase in contrast to the stimulus presented on trial $n - 1$ in the absence of feedback, similar to the increase we observed due to increasing ITI. Future work in which both ITI and feedback were manipulated should

provide a strong challenge for explaining contrast in absolute identification.

Finally, we highlight two particular benefits of using the Hierarchical Bayesian regression model. First, Bayesian statistics allowed us to argue in favour of the null hypothesis that there is no influence of ITI on assimilation to the previous response. This is important, as no existing model of assimilation predicted a null effect of ITI on assimilation. Second, assuming a hierarchical distribution for population parameters made our analysis robust to outliers. In Experiment 2, one participant's behaviour was unlike everyone else, largely because they were faster and more error prone. Interestingly, when the data were fit with a least squares regression and the resultant parameter estimates were analysed with standard null-hypothesis ANOVAs, whether the p -value for the interaction between ITI and within-block or between-blocks manipulation was less than .05 depended on the inclusion of this atypical participant. When they were excluded, the p -value was below .05, and when they were not excluded, the p -value was around .1. Assuming a hierarchical structure on the regression analysis meant that this participant's regression parameters underwent "shrinkage" towards the mean, and their inclusion had relatively little influence on inference made using Bayes factors. Overall, inference based on the Hierarchical Bayesian regression model account led to more robust inference from our data.

Original manuscript received 29 June 2013

Accepted revision received 3 June 2014

REFERENCES

- Brown, S. D., & Heathcote, A. J. (2008). The simplest complete model of choice reaction time: Linear ballistic accumulation. *Cognitive Psychology*, *57*, 153–178.
- Brown, S. D., Marley, A., Donkin, C., & Heathcote, A. J. (2008). An integrated model of choices and response times in absolute identification. *Psychological Review*, *115*, 396–425.
- Donkin, C., Brown, S., & Heathcote, A. J. (2011). Drawing conclusions from response time models: A

- tutorial using the linear ballistic accumulator model. *Journal of Mathematical Psychology*, 55, 140–151.
- Griffiths, T., Kemp, C., & Tenenbaum, J. (2008). Bayesian models of cognition. In R. Sun (Ed.), *Cambridge handbook of computational psychology* (pp. 59–100). Cambridge: Cambridge University Press.
- Holland, M. K., & Lockhead, G. R. (1968). Sequential effects in absolute judgments of loudness. *Perception & Psychophysics*, 3, 409–414.
- Jeffreys, H. (1961). *Theory of probability*. Oxford: Oxford University Press.
- Jordan, M. I. (2004). Graphical models. *Statistical Science*, 19, 140–155.
- King, J. A., Donkin, C., Korb, F. M., & Egner, T. (2012). Model-based analysis of context-specific cognitive control. *Frontiers in Psychology*, 3, 358. doi: 10.3389/fpsyg.2012.00358
- Lacouture, Y., & Marley, A. (1995). A mapping model of bow effects in absolute identification. *Journal of Mathematical Psychology*, 39, 383–395.
- Lee, M. D. (2008). Three case studies in the Bayesian analysis of cognitive models. *Psychonomic Bulletin & Review*, 15, 1–15.
- Lee, M. D., & Wagenmakers, E.-J. (2014). *Bayesian cognitive modeling: A practical course*. Cambridge: Cambridge University Press.
- Luce, R. D. (1986). *Response times*. New York, NY: Oxford University Press.
- Malmberg, K., & Annis, J. (2012). On the relationship between memory and perception: Sequential dependencies in recognition memory testing. *Journal of Experimental Psychology: General*, 141, 233–259.
- Marley, A. A. J., & Cook, V. T. (1984). A fixed rehearsal capacity interpretation of limits on absolute identification performance. *British Journal of Mathematical and Statistical Psychology*, 37, 136–151.
- Matthews, W., & Stewart, N. (2009a). The effect of inter-stimulus interval on sequential effects in absolute identification. *The Quarterly Journal of Experimental Psychology*, 62, 2014–2029.
- Matthews, W., & Stewart, N. (2009b). Psychophysics and the judgment of price: Judging complex objects on a non-physical dimension elicits sequential effects like those in perceptual tasks. *Judgment and Decision Making*, 4, 64–81.
- Miller, G. (1956). The magical number seven, plus or minus two: Some limits on our capacity for information processing. *Psychological Review*, 63, 81–97.
- Mori, S., & Ward, L. M. (1995). Pure feedback effects in absolute identification. *Perception & Psychophysics*, 57, 1065–1079.
- Pollack, I. (1952). The information of elementary auditory displays. *Journal of the Acoustical Society of America*, 24, 745–749.
- Ratcliff, R., & Rouder, J. N. (1998). Modeling response times for two-choice decisions. *Psychological Science*, 9, 347–356.
- Shiffrin, R. M., Lee, M. D., Kim, W., & Wagenmakers, E.-J. (2008). A survey of model evaluation approaches with a tutorial on hierarchical Bayesian methods. *Cognitive Science*, 32, 1248–1284.
- Stewart, N., Brown, G. D. A., & Chater, N. (2005). Absolute identification by relative judgment. *Psychological Review*, 112, 881–911.
- Triesman, M., & Williams, T. C. (1984). A theory of criterion setting with an application to sequential dependencies. *Psychological Review*, 91, 68–111.
- Van Ravenzwaaij, D., Mulder, M., Tuerlinckx, F., & Wagenmakers, E. J. (2012). Do the dynamics of prior information depend on task context? An analysis of optimal performance and an empirical test. *Frontiers in Psychology*, 3, 132. doi: 10.3389/fpsyg.2012.00132
- Viviani, P. (1979). A diffusion model for discrimination of temporal numerosity. *Journal of Mathematical Psychology*, 19, 108–136.
- Wagenmakers, E.-J., Lodewyckx, T., Kuriyal, H., & Grasman, R. (2010). Bayesian hypothesis testing for psychologists: A tutorial on the Savage-Dickey procedure. *Cognitive Psychology*, 60, 158–189.
- Ward, L. M., & Lockhead, G. R. (1970). Sequential effect and memory in category judgment. *Journal of Experimental Psychology*, 84, 27–34.
- Ward, L. M., & Lockhead, G. R. (1971). Response system processes in absolute judgment. *Perception & Psychophysics*, 9, 73–78.
- White, C. N., Mumford, J. A., & Poldrack, R. A. (2012). Perceptual criteria in the human brain. *Journal of Neuroscience*, 32, 16716–16724.
- Zotov, V., Jones, M., & Mewhort, D. J. K. (2011). Contrast and assimilation in categorization and exemplar production. *Attention, Perception, & Psychophysics*, 73, 621–639.